

MATERIALS

1. HOUSING : THERMOPLASTIC (UL 94V-0).
2. TERMINAL : COPPER ALLOY.
3. SHELL : STEEL.

SPECIFICATION

1. CURRENT RATING : 5 AMP. MAX.
2. DIELECTRIC WITHSTANDING VOLTAGE : 1000V AC R.M.S. FOR ONE MINUTE.
3. INSULATION RESISTANCE : 1000M OHMS MIN. AT 500V DC.
4. OPERATING TEMPERATURE : -55°C TO +105°C.
5. MAX. PROCESSING TEMP. : 230°C FOR 30 ~ 60 SECONDS.

ORDER INFORMATION :

HD6C * - ** - * M A N * *

SERIES CODE

HOUSING OPTIONS
 BLANK : NORMAL
 H : HI.-TEMP. PLASTIC

NUMBER OF POSITION

MOUNTING OPTIONS
 REF. DRAW NO. C400-0005-1

MALE

SOLDER TAIL PLATING OPTIONS
 G : GOLD
 T : TIN

CONTACT PLATING OPTIONS
 1 : GOLD FLASH
 2 : .000010" GOLD
 3 : .000015" GOLD
 5 : .000030" GOLD

NICKEL PLATING ON SHELL

BLACK IN HOUSING COLOR

REV.	DESCRIPTION	DATE
A	RELEASE	Jul. 18, 2000
B	P/N MODIFY	Jun. 1, 2001
C	P/N MODIFY	Aug. 20, 2002
D	P/N MODIFY	Aug. 26, 2002
E	DRAW MODIFY	Mar. 09, 2004

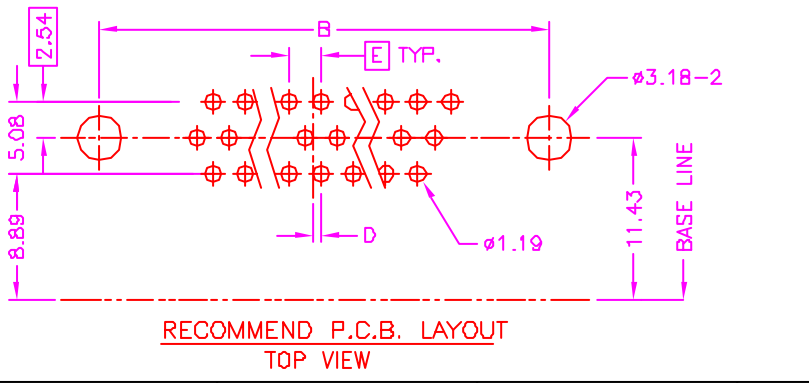
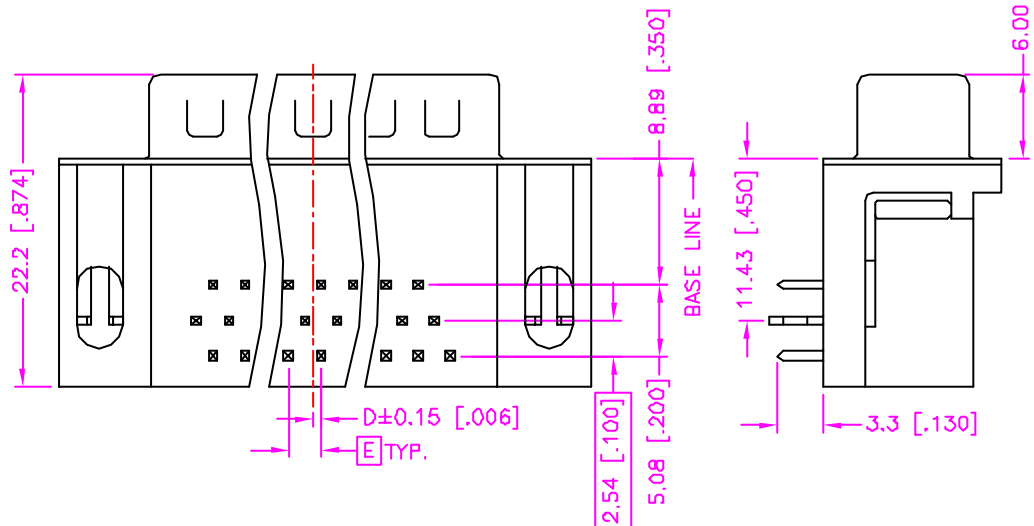
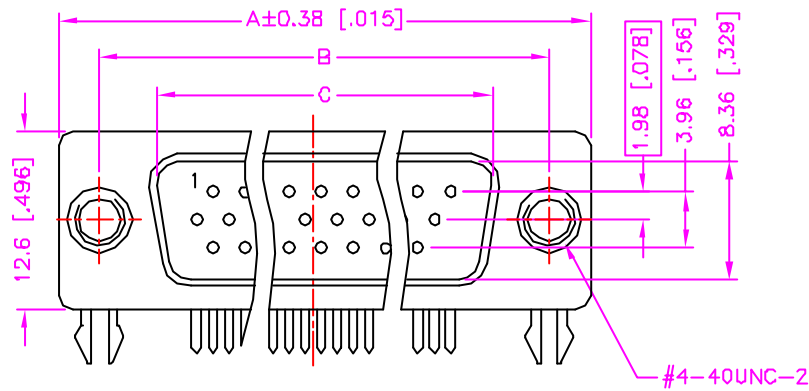

Number Of Position	Dimensions				
	A	B	C	D	E
15	30.81[1.213]	24.99[.984]	16.92[.666]	0.25[.010]	2.29[.090]
26	39.14[1.541]	33.32[1.312]	25.25[.994]	0.25[.010]	2.29[.090]
44	53.04[2.088]	47.04[1.852]	38.88[1.534]	0.51[.020]	2.29[.090]
62	69.32[2.729]	63.50[2.500]	55.42[2.182]	0.58[.023]	2.41[.095]

TOLERANCE .0 = ± 0.38 [.015] .00 = ± 0.25 [.010] .000 = \pm .0000 = \pm ANG. = $\pm 3^\circ$	DRAWER SUB CHECK Katharin APP'D ALBT	 WWW.ASTRON.COM.TW NAME HIGH DENSITY D-SUB P.C.B. MOUNT RIGHT ANGLE 8.89mm/0.350" FOOTPRINT MALE		
UNITS : mm [inch]	PRODUCT SPEC. 412-0011		DRAW NO. C415-0005	
SCALE NONE	SIZE A4	SHEET 1 OF 1	REV. E	07002/14001/10004

MOUNTING OPTIONS

REV.	DESCRIPTION	DATE
A	RELEASE	Aug. 21, 2000
a	ADD TYPE P	Nov. 29, 2000
c	DRAW MODIFY	Aug. 06, 2002
o	DRAW MODIFY	Nov. 24, 2003
E	DRAW MODIFY	Jan. 14, 2004

A TYPE (STANDARD)

WITH #4-40UNC THREADED INSERT & HARPOON GROUNDING BRACKET 8.00mm TYPE

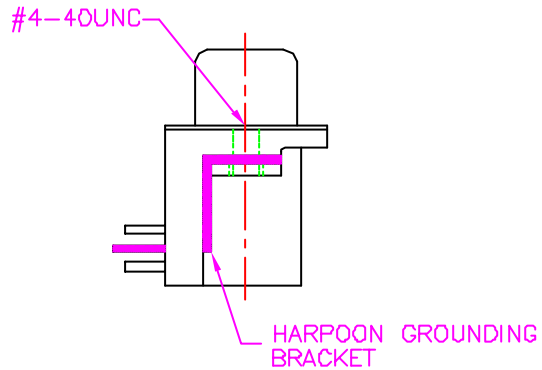

B TYPE

WITH #4-40UNC THREADED INSERT & BRACKET

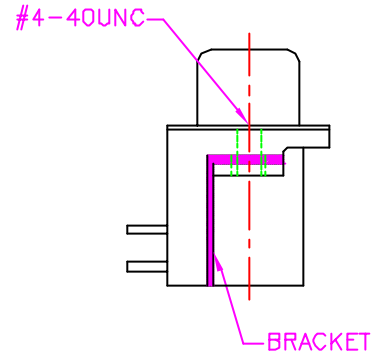

C TYPE

WITH FIXED #4-40UNC HEX NUT & HARPOON GROUNDING BRACKET

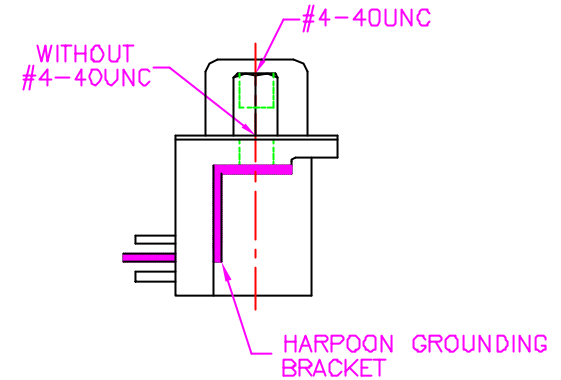

F TYPE

WITH #4-40UNC HEX NUT SCREWLOCK & HARPOON GROUNDING BRACKET

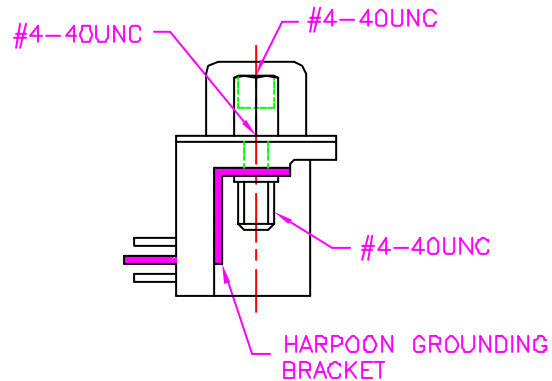

P TYPE

WITH #4-40UNC THREADED INSERT & #4-40UNC HEX NUT SCREWLOCK & HARPOON GROUNDING BRACKET

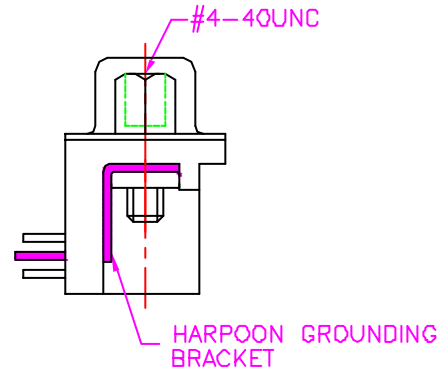

TOLERANCE		DRAWER	Astron ASTRON TECHNOLOGY CORP.
.0=±.		<i>SUB</i>	
.00=±.25 [.010]		CHECK	NAME D-SUB SERIES MOUNTING OPTIONS
.000=±.		<i>Kathleen</i>	
.0000=±.		APP'D	DRAW NO. C400-0005-1
ANG.=±3°		<i>LSOX</i>	
		PRODUCT SPEC.	
UNITS : mm [inch]			
SCALE NONE	SIZE A4	SHEET 1 OF 1	REV. E